

ADGERO

WWW.ADGERO.CO.UK

CONTACT: MACK_MURRAY@ADGERO.EU

HYBRID RETROFIT FOR TRUCKS

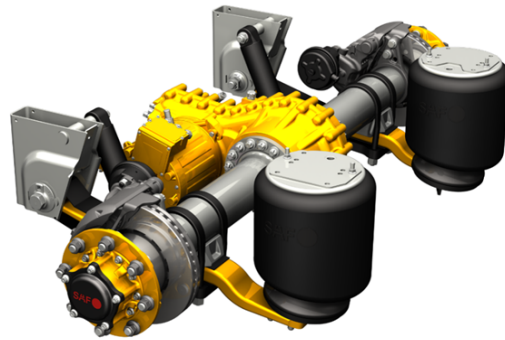
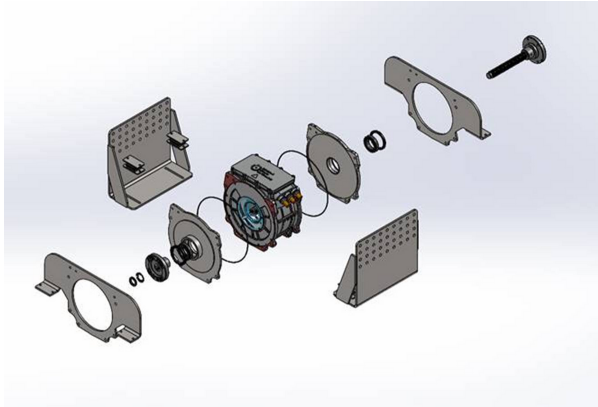

CURRENT CUSTOMERS

COMBINED
TURNOVER
> 5 BILLION

VEHICLES
> 60 000



TEAM



Mack Murray CEO

Developed KERS concept while consulting at Mercedes-Benz CTT on the Armoured Recovery project. Mack holds an MSc. in Education Science from the University of Strasbourg.



Rory Oliver-Hall Chief Hardware Engineer

Chartered Engineer and a member of the Institute of Engineering Technologies. Developed Hybrid drivetrains for Jaguar Land Rover.

Will Putter CCO

HGV retrofit field since 2002, rolling out dual fuel diesel and CNG HGV systems with major UK and European haulage companies.



Frédéric Soulier CSO

Professor of Embedded Systems Engineering at University of Strasbourg. Former CTO of Caldera Graphics, where he was a key player in their acquisition by Dover Corp.



Deborah Hudson NED Acting CFO

Electrical Engineering MEng and an MBA from Insead. After a decade at McKinsey, she is now a partner at Shackleton Ventures, where she leads their transport innovation investment strategy.



RAISING \$2 MILLION IN 2021 TO SUPPORT US LAUNCH