



What is the Dynamic Combustion Chamber™ (DCC)?

DCC is a breakthrough boiler that enables the transformation of H₂ and O₂ to high value steam without generating any air pollutants. It does not require a smokestack or any other energy dissipating exhaust, and is nearly 30% more efficient in fuel usage than a typical conventional steam boiler.

Key Features:

- >95% efficient thermal condensing hydrogen steam generator
- ZERO emission design - heat and water only byproducts
- Refractory lined reaction box
- Fire free heat transfer tubes
- Reverse superheat steam tube design for maximum condensation
- 100% Water Fuel Recycled
- Endorsed by San Joaquin Unified Air Pollution Control District
- ASME code constructed & stamped
- UV flame detector
- Flame observation ports
- Steel skids and lifting eyes

- A. 5MW Boiler
- B. Torricellian Column
- C. Feed Water Skid
- D. Blow Down Separator
- E. Boiler Support Structure
- F. Turbine Condenser

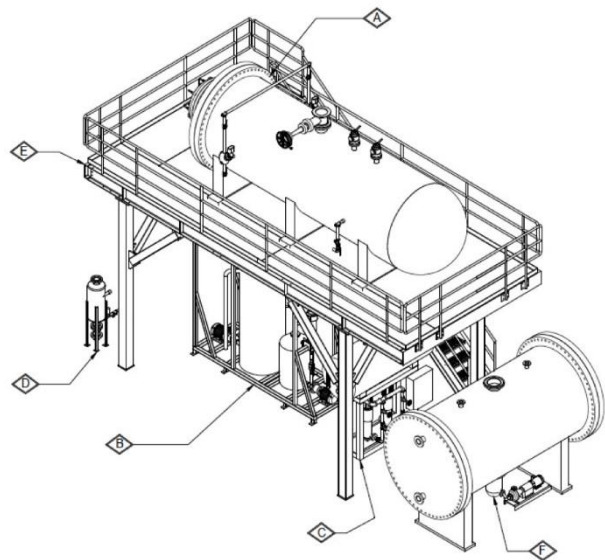

DCC-0100	DCC-1000	DCC-5000	DCC-10000
To produce sufficient steam to drive a 100 kW Siemens SST-040 micro-steam turbine genset.	To produce sufficient steam to drive a Siemens SST-110 turbine genset up to 1 MWe capacity.	To produce sufficient process steam to drive a Siemens SST-110 turbine genset up to 5 MWe capacity.	Composed of twin DCC-5000 in parallel to produce process steam or drive a Siemens SST-110 turbine genset up to 10 MWe capacity.
STEAM OUTPUT RATE			
1,360 Kg/hr 2,992 lbs/hr	6,000 Kg/hr 13,200 lbs/hr	28,182 Kg/hr 62,000 lbs/hr	56,364 Kg/hr 124,000 lbs/hr
OUTLET PRESSURE			
Up to 40 bar / 580 psi		Up to 40 bar / 580 psi	
STEAM TEMPERATURE			
Up to 400°C / 752°F	Up to 400°C / 752°F	Up to 400°C / 752°F	Up to 400°C / 752°F
H₂ FUEL CONSUMPTION			
Up to 30 Kg/hr 67 lbs/hr	Up to 123 Kg/hr 270 lbs/hr	Up to 568 Kg/hr 1,250 lbs/hr	Up to 1,136 Kg/hr 2,500 lbs/hr
DIMENSIONS(L X W X H)			
576 x 376 x 569 cm	732 x 465 x 645 cm	884 x 465 x 686 cm	844 x 930 x 686 cm
227 x 148 x 224 in	288 x 183 x 254 in	348 x 183 x 270 in	348 x 366 x 270 in

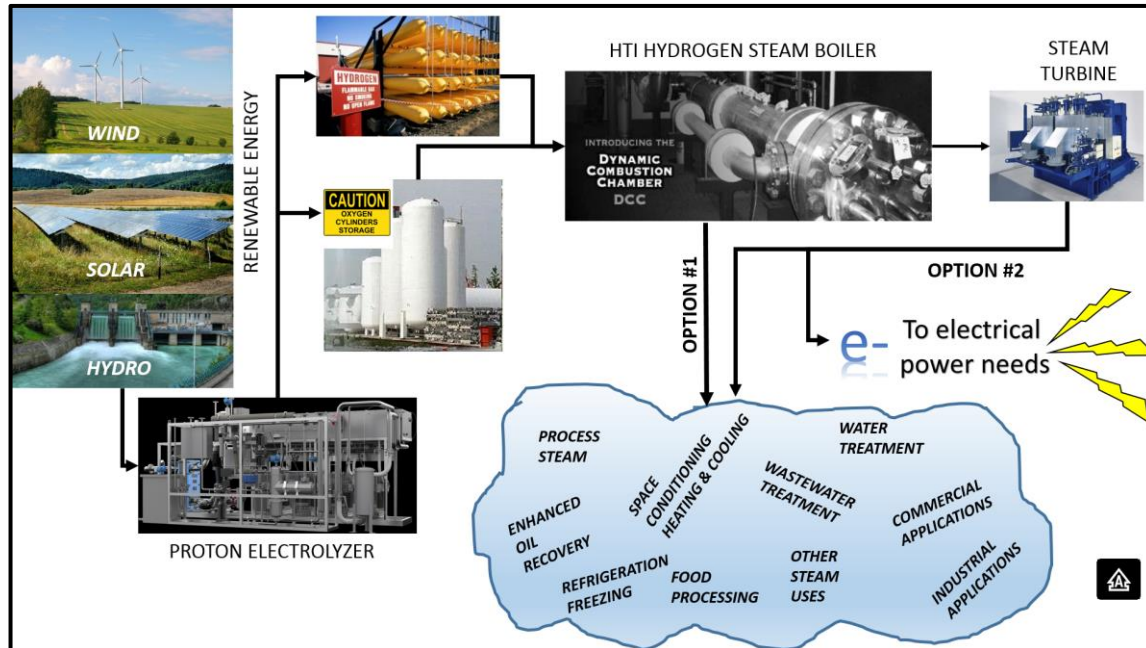

HYDROGEN TECHNOLOGIES INC
 34 S. California St.
 Stockton, CA 95202
 PHONE/FAX: +01-209-565-2197
www.hydrogentechnologiesinc.com

Applications:

- Industrial and commercial
- power generation
- space conditioning
- water and wastewater treatment
- food processing
- process steam generation



PHONE: +01-203-949-8697
 FAX: +01-203-949-8016
<http://protononsite.com/contact/general.html>

Combined with H₂ fuel from water electrolysis driven by renewable energy, DCC™ can be deployed in microgrid systems, offering several advantages over alternative storage approaches:

- A modular durable package design allows a wide variety of configurations to satisfy commercial and industrial needs in the most economical way.
- Variations or flexibility is achieved by selecting from a number of pre-defined heat transfer tubes with appropriate fuel consumption stages for incorporation into the standard design.
- Proven components assure high reliability and easy maintenance.

Each industrial steam generator is available as a freestanding machine for steam only or as a customized package which includes the turbine, generator, gearbox, and all other auxiliary systems, mounted together on one or more base frames for Combined Heat and Power (CHP).

Please ask about our Thermal Fluid Heater Systems delivering renewable, emission free, heat using Duratherm™ 600¹ as the heat transfer fluid.

¹ <https://durathermfluids.com/heat-transfer-fluid/duratherm-600/>