

Core Concepts

A Solar thermal vs solar photovoltaic

The sun's thermal heat powers our SOLAR POLAR cooling units. This differs from the Solar you're probably thinking about which is Solar Photovoltaic (PV). Solar thermal technology harnesses the sun's heat energy and uses it to directly cool your house or run your fridge. This is much more efficient than Solar PV which collects the sun's energy and turns it into electricity, which is then used to power appliances to cool your home.

B Concept of absorption refrigeration

Our cooling units use the absorption refrigeration method to cool your home. The system uses coolants, where heat from the sun evaporates liquid ammonia in a low partial pressure environment. It extracts the localised heat and cools it before pumping it throughout your home.

C Closed loop system

Our system, comprised of no moving parts does not require any external energy or power to run; all it needs is the heat from the sun. All of the coolants are non ozone depleting or global warming and just go round and round in this sealed unit ensuring a very long system lifespan with very little maintenance. The system uses the sun's heat and earth's gravity to keep this looped system running infinitely. Using cool storage, it can even run during the night.

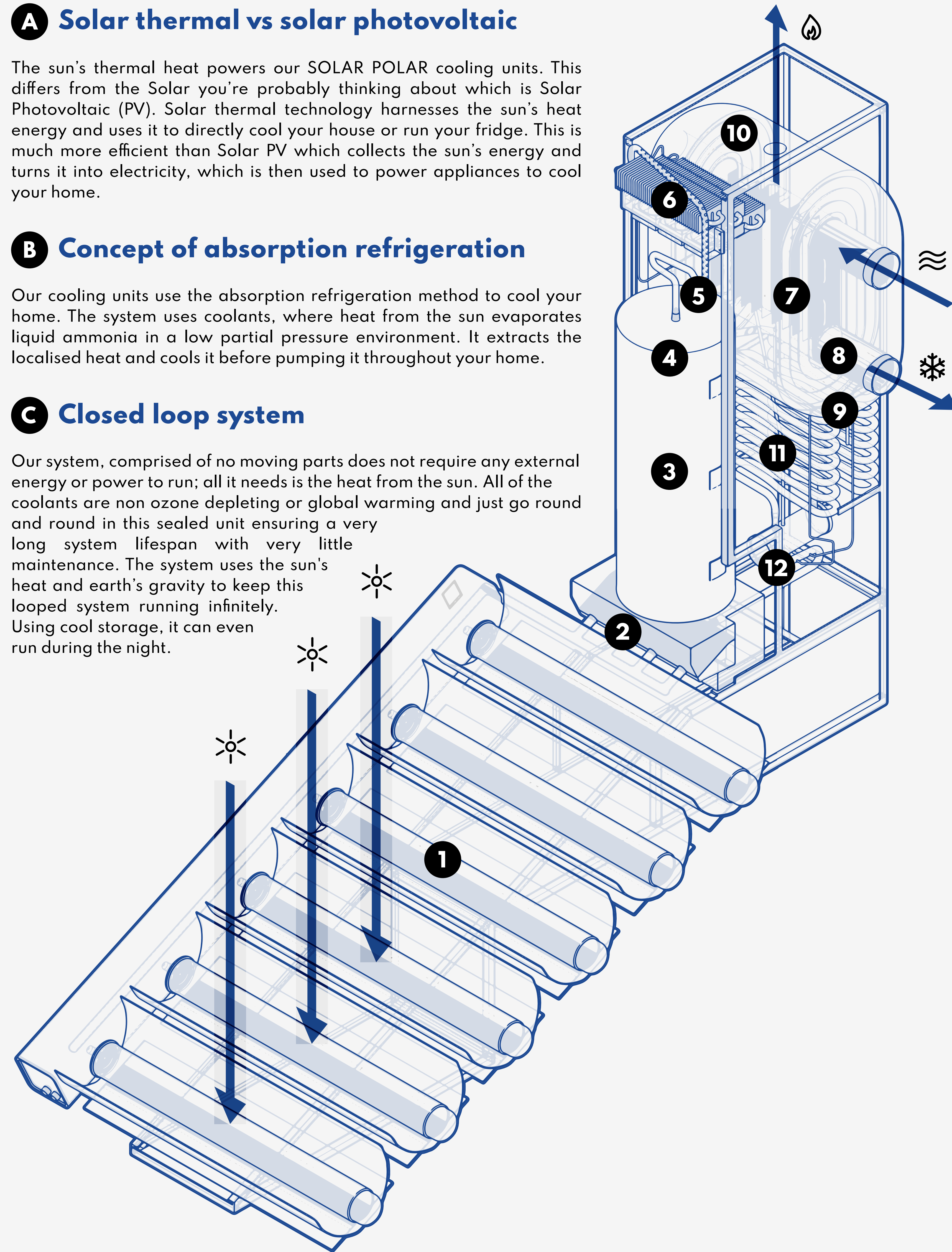

Solar Polar Module

How it works

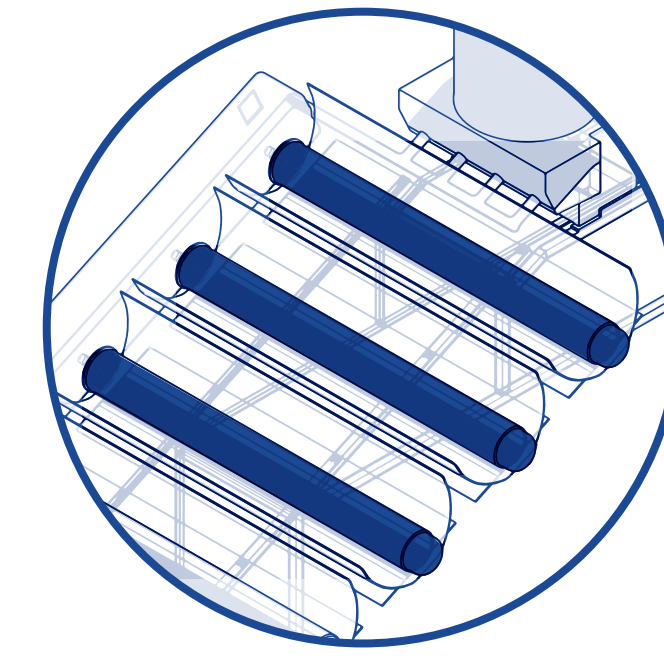

1 Solar collector
The solar collectors are filled with water and have large parabolic mirrors beneath them which reflect the sunlight into the collector throughout the day.

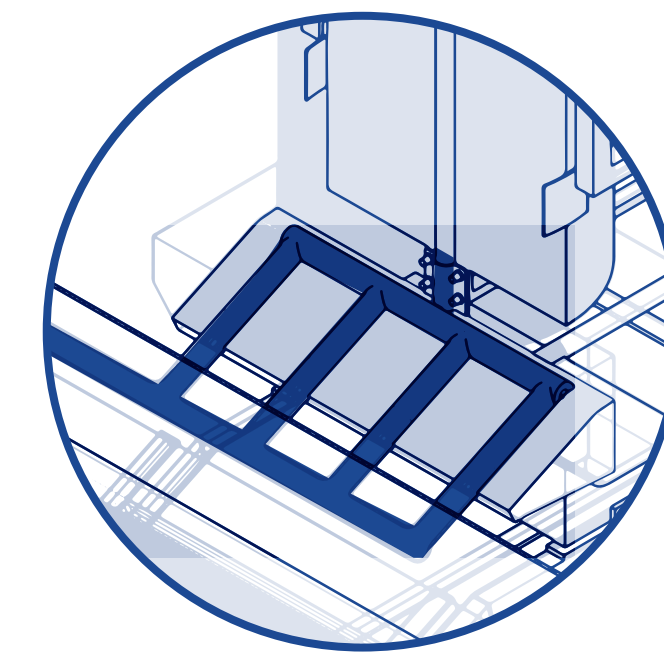

2 Heat pipe
The heat pipe moves the heat generated from the solar collectors (1). It does this by shifting the energy through the water in a vacuum where the heat is then transferred to the generator (3).

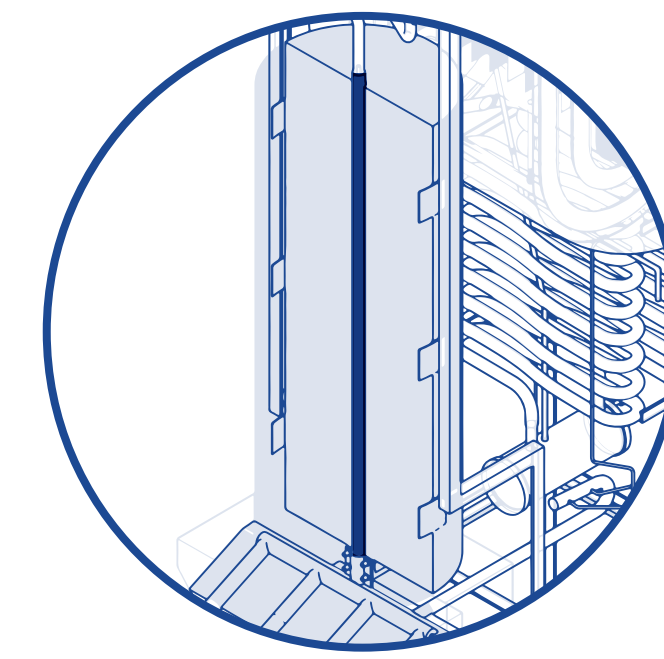

3 Generator
The heat energy from the heat pipe is transferred into the generator where it then boils the ammonia water solution turning the ammonia into a gas. The temperatures will reach upwards of 200°C so it is heavily insulated with thick insulation around the system.

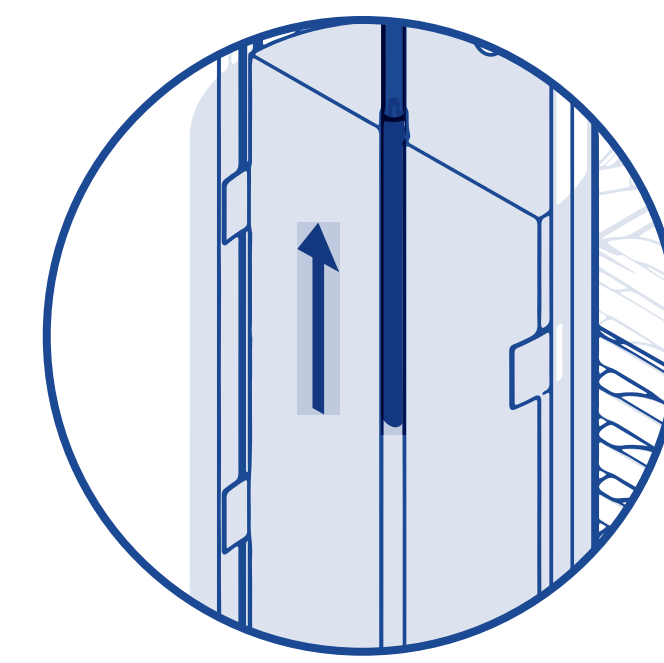

4 Bubble pump
As the generator boils the solution the bubble pump located inside the generator raises the ammonia gas up to the rectifier (5) from the bottom of the generator.



5 Rectifier
The rectifier separates any remaining water from the ammonia mixture and funnels it back using the gravity-fed system to the reservoir (12) via the absorber (11). The ammonia gas continues up to the condenser (6).

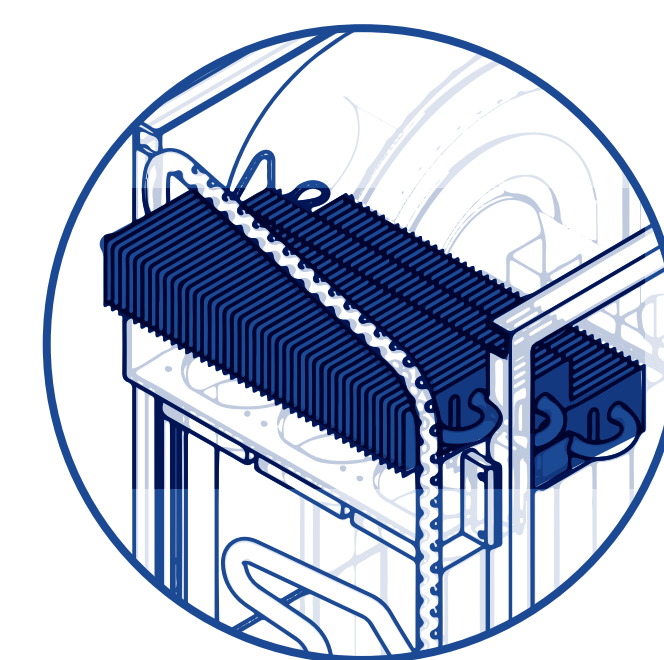

6 Condenser
The ammonia gas condenses into ammonia liquid as it travels down the sloped system, pooling in the trap which stops hydrogen from back flowing into the condenser.

Diagram

- Sunlight
- Liquid
- Gas
- Hot
- Cold
- Air
- Movement
- Condensate
- Evaporate
- Sunlight
- Thermal heat
- Ammonia water
- Ammonia
- Hydrogen
- Hydrogen ammonia
- Cool air
- Water
- Outside air
- Convected air
- Module housing

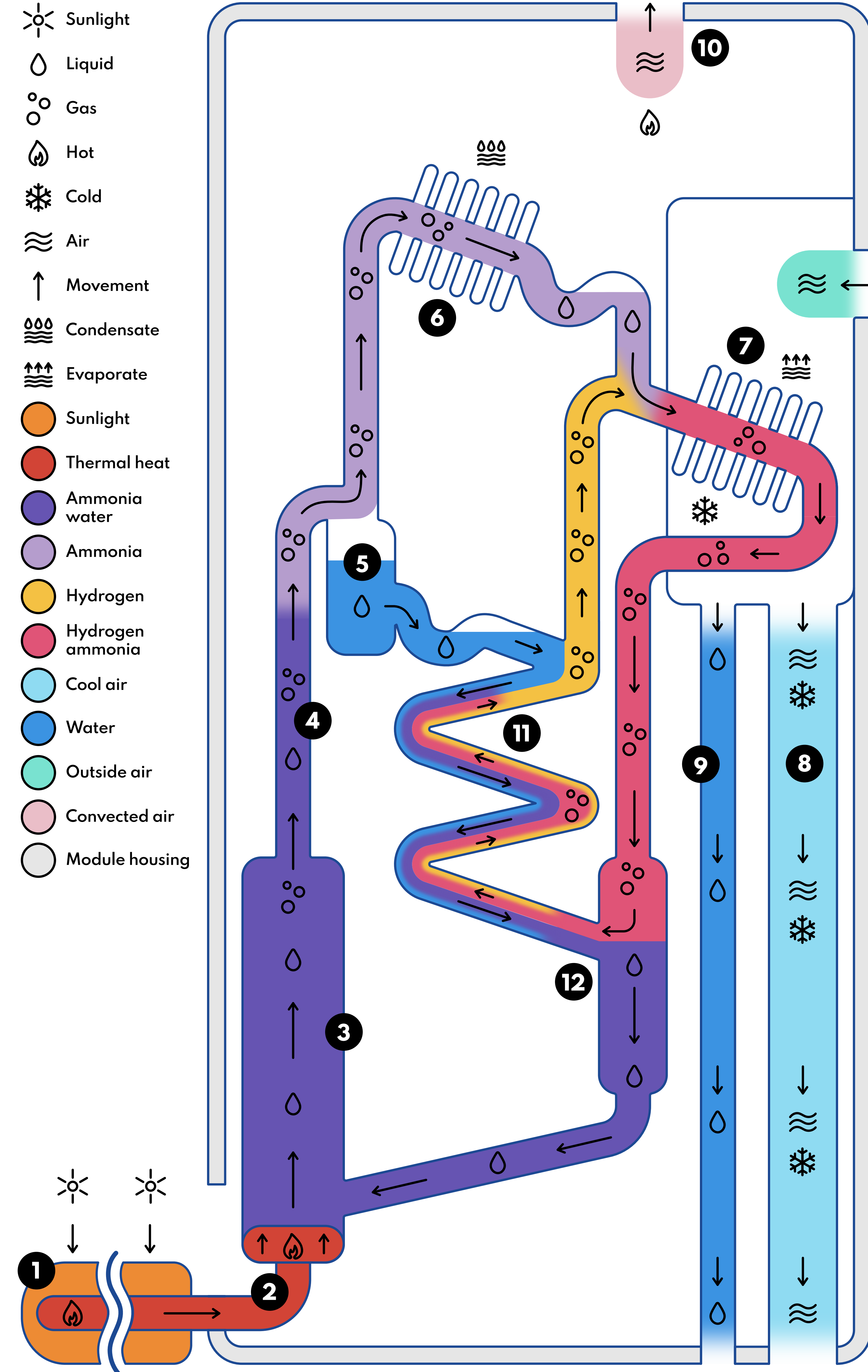

7 Evaporator
The Evaporator is where the magic happens. In the upper section the condensed ammonia gas meets pure hydrogen and by the law of partial pressures, it causes the ammonia to evaporate, cooling the air within the system. The heavier mixed solution then moves further down the system to the reservoir (12).

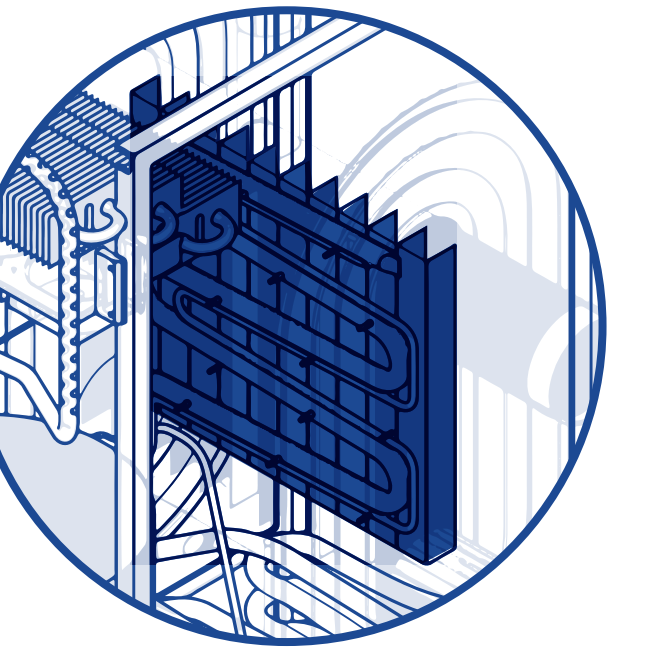

8 Cool air
The cool air generated from the evaporator is funnelled out of the unit and is pushed into your home or refrigeration unit.

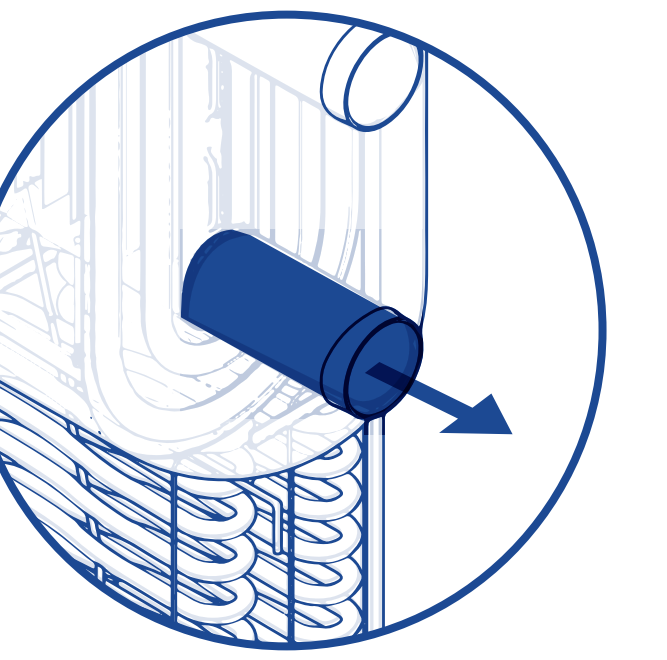

9 Condensed water
Condensed water from dehumidifying your air is fed out of a condensate pipe at the base of the unit. In areas where water is scarce, this water can be used, for example, to water plants or boiled to make tea.

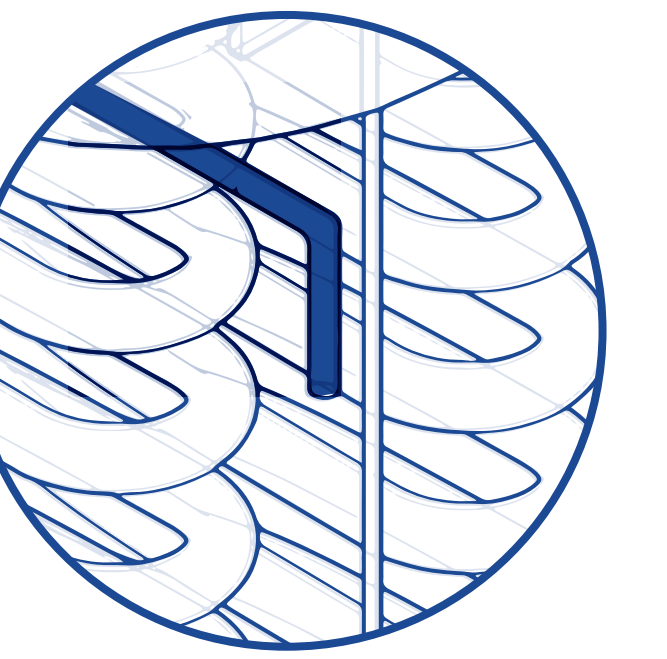

10 Convected air
Hot convected air which is rejected heat generated from around the condenser (6) and evaporator (7) rises out the top of the unit, back into the atmosphere.

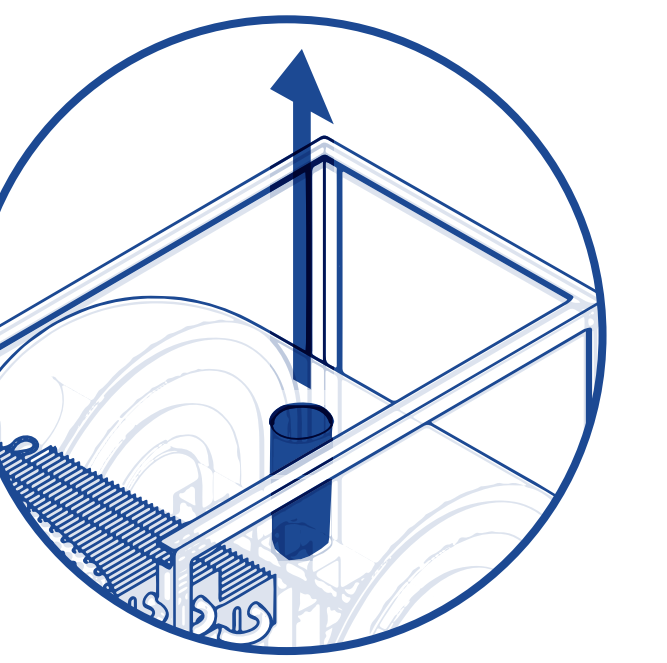

11 Absorber
When the hydrogen gas saturated with ammonia reaches the reservoir (12) it starts to travel back up the absorber where it meets the water passed down from the rectifier (5). As the gas and the water pass each other the water reabsorbs the ammonia, creating the ammonia water solution while leaving behind pure hydrogen which then travels up to the evaporator (7).

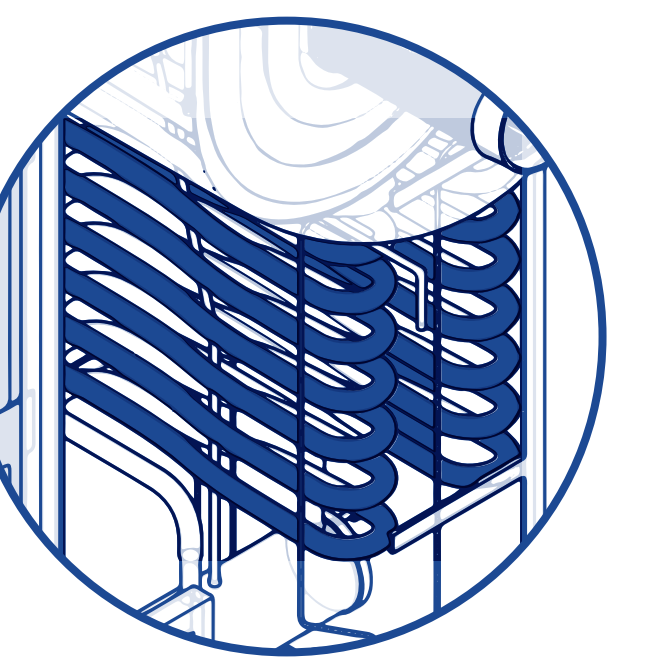

12 Reservoir
The new ammonia water solution flows into the reservoir and then down to the generator (3) to start the cooling cycle over again. The closed-loop system continually repeats the process throughout the daylight hours providing an excellent source of refrigeration or cooling.

