



H2Omni-X

Modular unmanned surface vehicle

One-man portable multifunctional USV with exchangeable payload



Applications

Inspection and Monitoring

Inspection and monitoring of marine environment and infrastructure has never been easier!

Mapping and surveying

H2Omni-X is suitable for mapping and surveying both confined spaces and open waters.

AUV and Diver Tracking

Tracking and communicating with personnel and equipment will improve and secure all your underwater activities.

Research

Being modular, scalable and using open-source software, H2Omni-X is a perfect platform for R&D purposes.

Characteristics

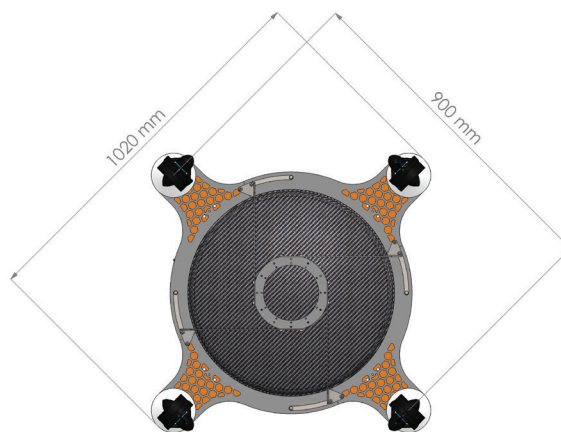
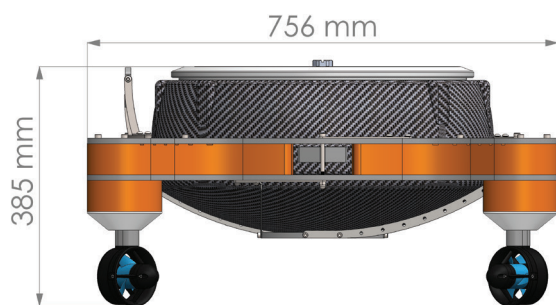

Lightweight	15kg + battery ¹
Highly maneuverable	Omnidirectional with dynamic positioning
Open source software architecture	ROS Kinetic on Ubuntu
Thrust and speed	4 x thruster ; max speed: 1.0 m/s ²
Housing	Waterproof monocoque carbon-fiber shell, PVC floaters
On-board computer	i3 to i7, SSD, up to 32GB RAM
Power	12V AGM Gel Battery ¹
Connectivity	Wireless (2.4 GHz network) and Wire (ethernet)
Control	Autonomous mode ³ Manual mode: Radio Control, Joystick over Wi-Fi
Navigation	IMU, GPS / RTK, Acoustics
Additional equipment	Underwater and above-water video cameras, sonars, acoustic modems

¹ Lithium battery optional

² Speed with 200W thrusters, option to upgrade

³ Capabilities: go-home, mission planning, object following, formation keeping, collision detection and avoidance

H20mni-X* participated in European and other projects:

- **CADDY** - Cognitive Autonomous Diving Buddy (EU FP7)
- **subCULTron** - Long-Term Robotic Exploration of Unconventional Environmental Niches (EU Horizon2020)
- **PlaDyFleet** - A fleet of unmanned surface marine vehicles PlaDyPos (EU Horizon2020, RAWFIE)
- **BLUEMED** (EU Interreg Mediterranean)
- **CroMarX** - Cooperative robotics in marine monitoring and exploration (Croatian Science Foundation)
- **e-URready4OS** - Expanded underwater robotics ready for oil spills (Directorate-General Humanitarian Aid and Civil Protection – EUROPEAN CIVIL PROTECTION AND HUMANITARIAN AID OPERATIONS)

* previously known as aPad and PlaDyPos